

**1 Mark and drill door.**  
 Start approx 990mm from the floor, fold and apply the supplied template and mark 2 centre points at your desired backset of 60mm or 70mm. Using a 2.5mm drill bit, drill to a depth of 5mm using the marked holes.

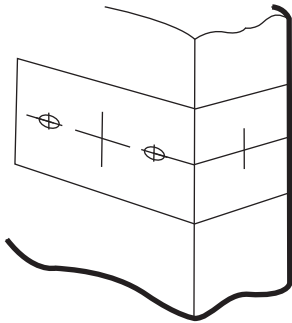

**2 Remove the Knob from base.**  
 Using the pin supplied, press the anchor point and remove the knob from the base. and release the rose from the chassis.

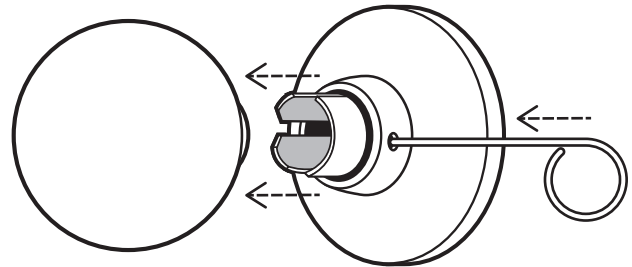

**3 Install the base.**  
 Using the 2x supplied screws, align and install the chassis onto the door using the pre-drilled holes. Place rose over the chassis and press firmly to secure, aligning the tabs.

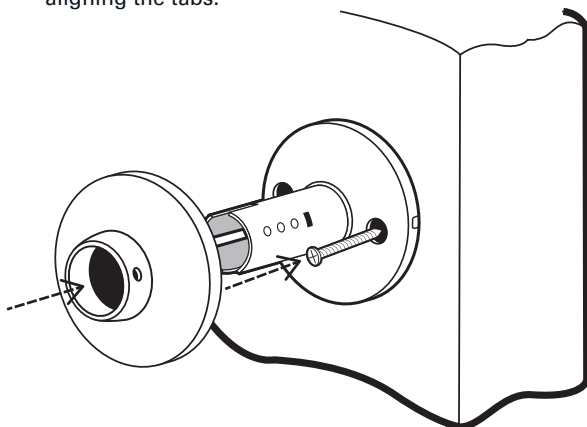

**4 Attach knob.**  
 Install the knob by aligning on the base and sliding on firmly until it clicks.

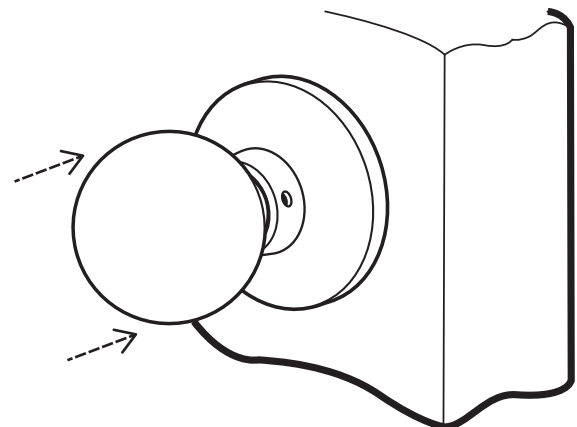

*With this fixed dummy set we recommend using our MC1 Magnet, visit our website for further information.*

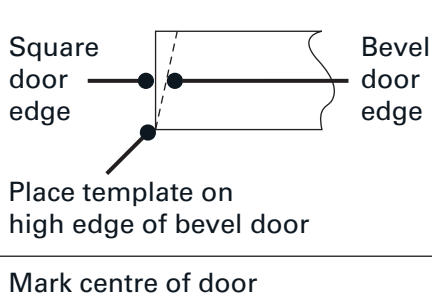

For 70mm backset fold here

For 60mm backset fold here

Drill 2.5mm holes x 2  
5mm Deep

42mm