

# BASE CABINET 1 SHELF

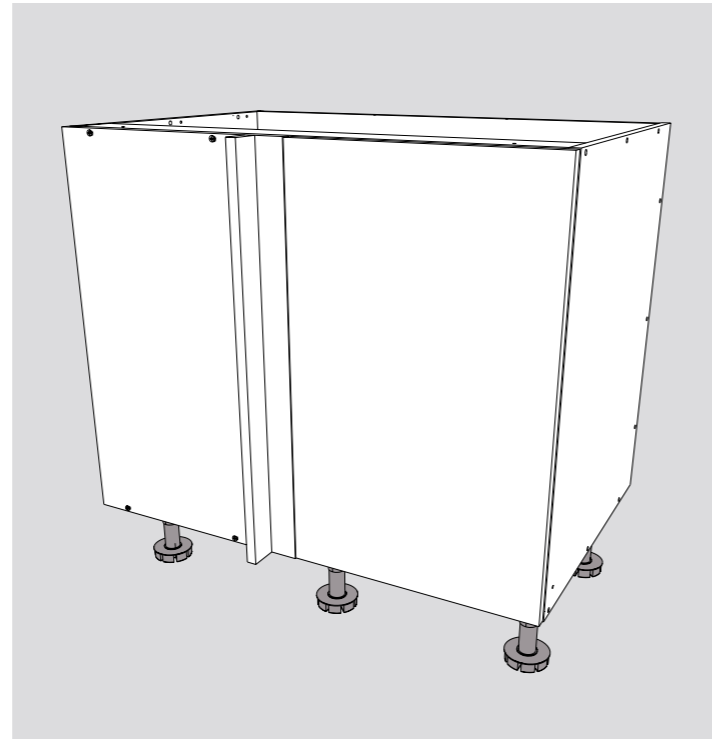

## Assembly Instructions

Suitable for Base Cabinets:  
BR900-IMP

Art. 732.25.812

**Handy Note:** Please read the instructions carefully before you start and make sure to identify the parts you need for each step. When assembling it is best to do on a soft surface to prevent damage.

### Cabinet Panels included.

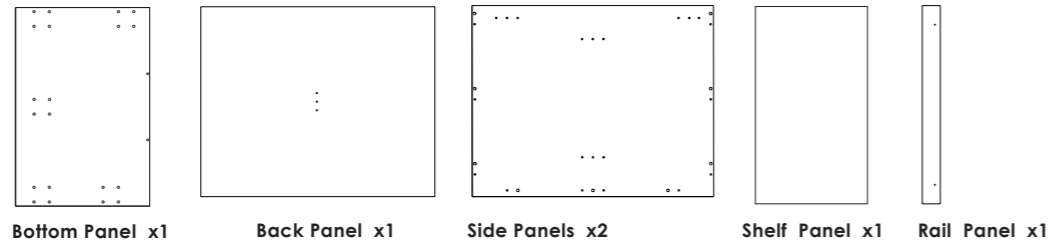

### HÄFELE Hardware included.

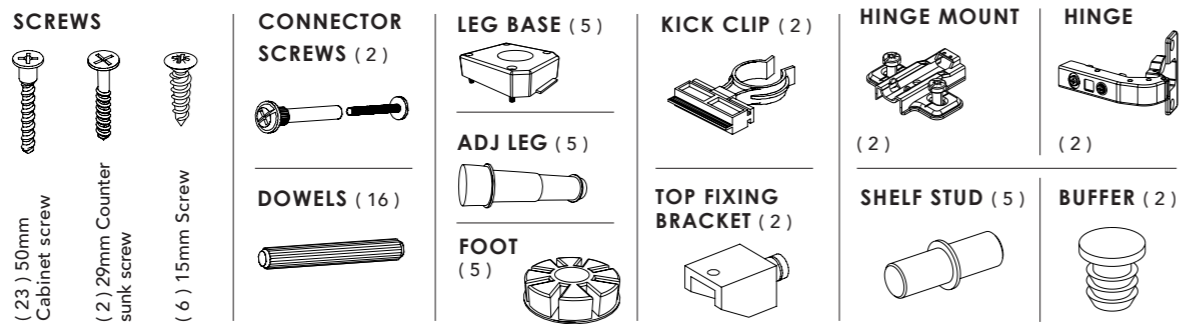

### Required Tools.

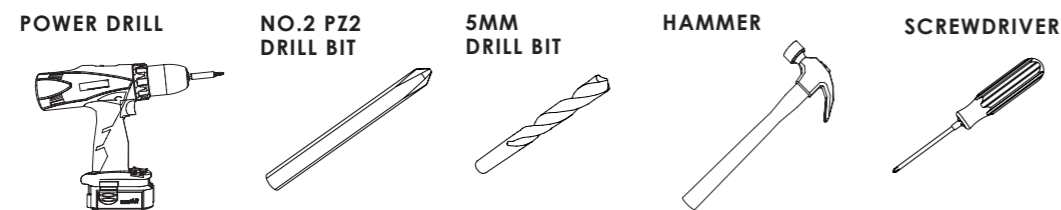

### Handy Tools.

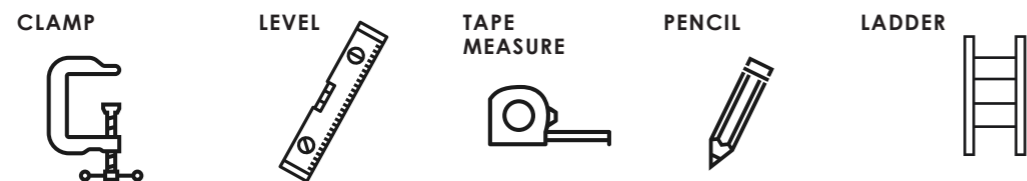

Manufactured in New Zealand for: Mitre 10 New Zealand Limited.

## 1. Installing Leg Bases.

- Fix the Leg bases by aligning them on the base panel as shown.
- Ensure dowels in the leg bases line up with the holes. Use a block of wood between leg base and mallet to prevent damage before striking it into place.

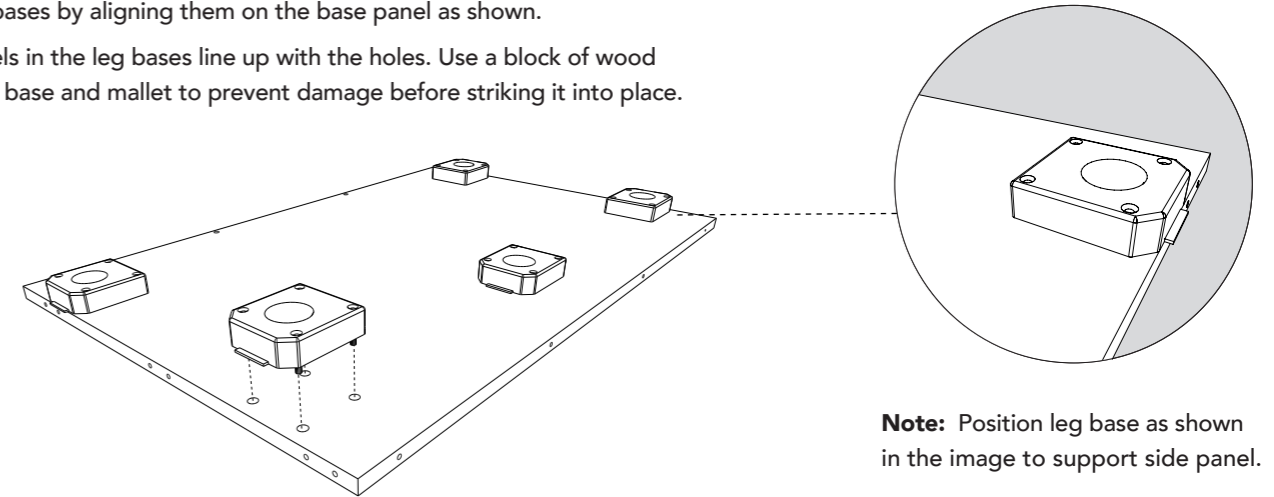

**Note:** Position leg base as shown in the image to support side panel.

## 2. Fixing Bottom and Back Panels.

- Lay the back down flat as shown.
- Use 50mm cabinet screws to fix the bottom panel to the back panel.

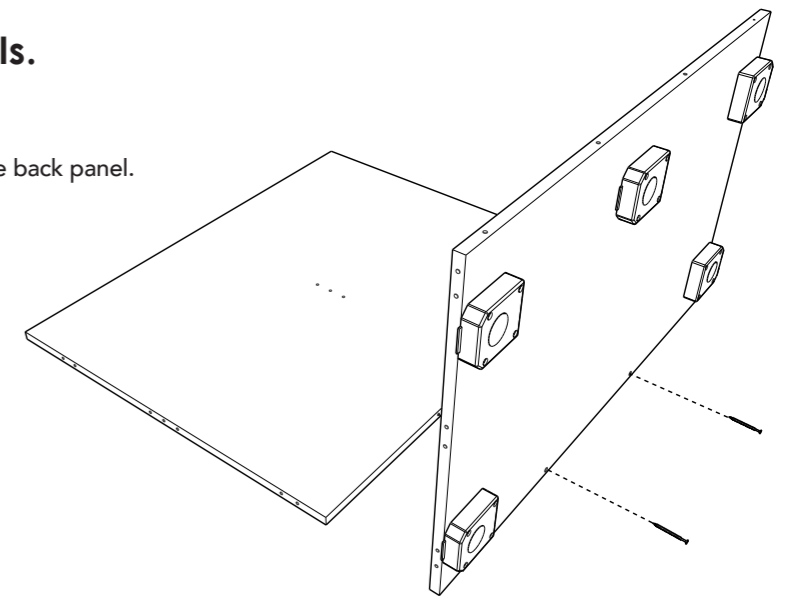

## 3. Inserting Dowels into Side Panels

- While laying the panels flat, insert the dowels into the holes marked with arrows in the diagram.

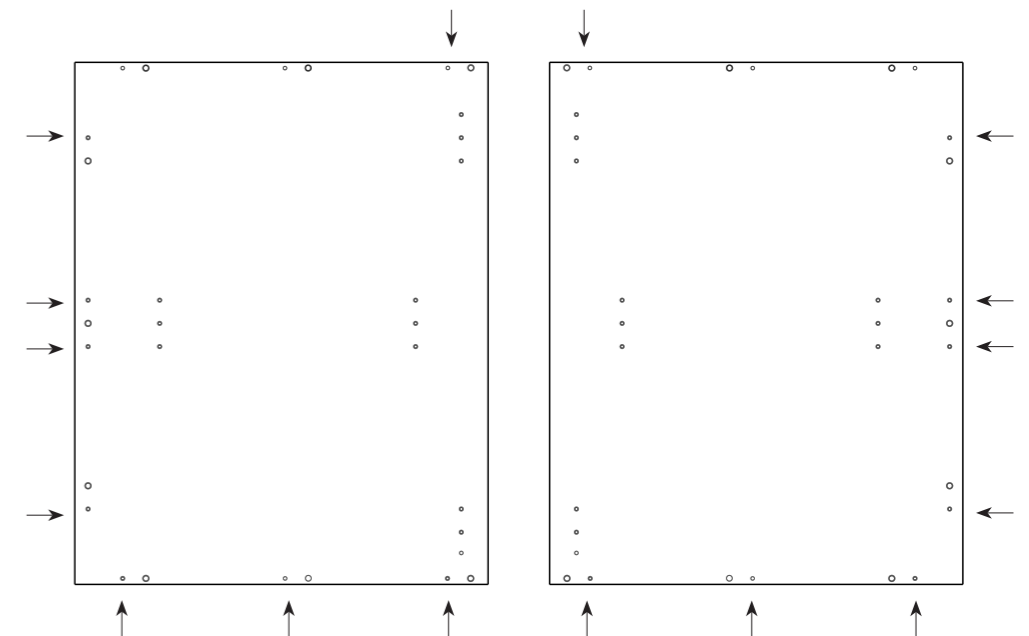

## 4. Fixing Side & Rail Panels to Base & Back .

- Align the base and back panels with the dowels on the side panel.
- Align the base and back panels with the dowels on the side panel.
- Lift the second side panel to ensure dowels are aligned with the corresponding holes. Use 50mm cabinet screws to fix the rail, back and bottom panels to the side panel.
- Flip the cabinet to secure the other side panel with back, base and rail panels using 50mm cabinet screws.

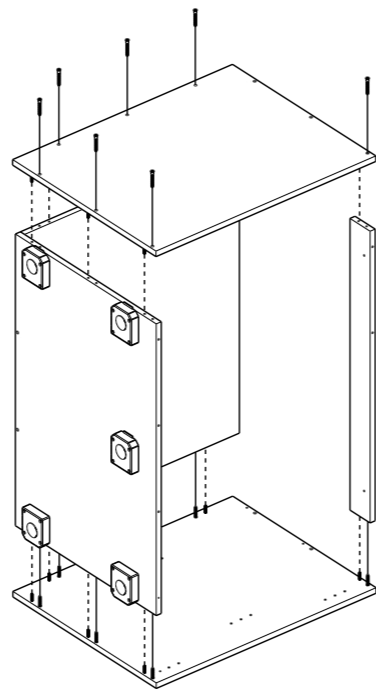

## 7. Fixing Hinge Mounts to Return Panels.

- Fix small return panel to large return panel using 50mm Cabinet Screws.
- Screw fix the hinge mounts to the side panels as shown.

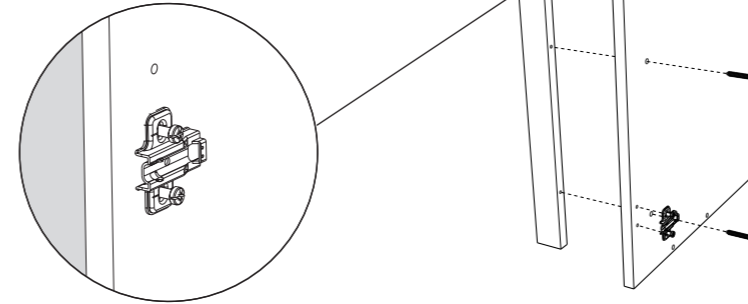

- Screw fix the big return panel to the carcass using cabinet screws. **Note:** Check if the cabinet needs to be left hand or right hand before fixing the return panel.

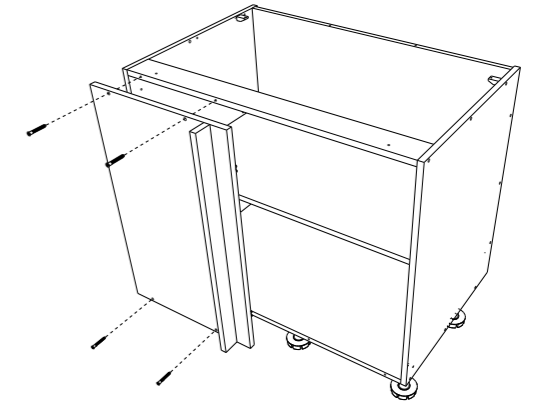

## 5. Fixing leg and foot to leg base.

- **Cabinet Feet:** Push the supplied adjustable leg into the foot and then insert it into the leg base attached to the base panel.
- Height of the Legs =  $\pm 150\text{mm}$
- Height of the Cabinet = 720mm
- Height of Cabinet + Legs = 870mm

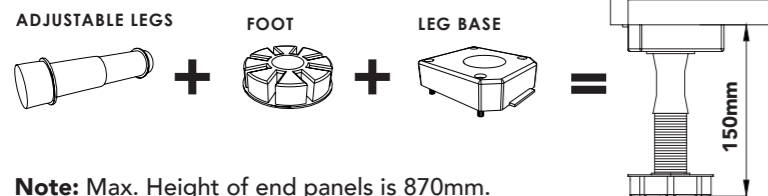
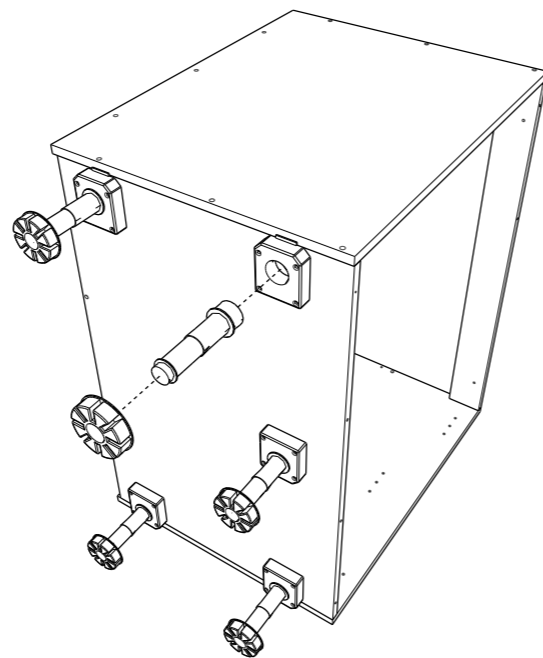

## 8. Fixing Hinges to Return Panels.

- Fix the hinges using 15mm screws as shown.
- Clip doors onto the unit. See hinge installation for further details.
- **Note:** Door Front and return panels sold separately.

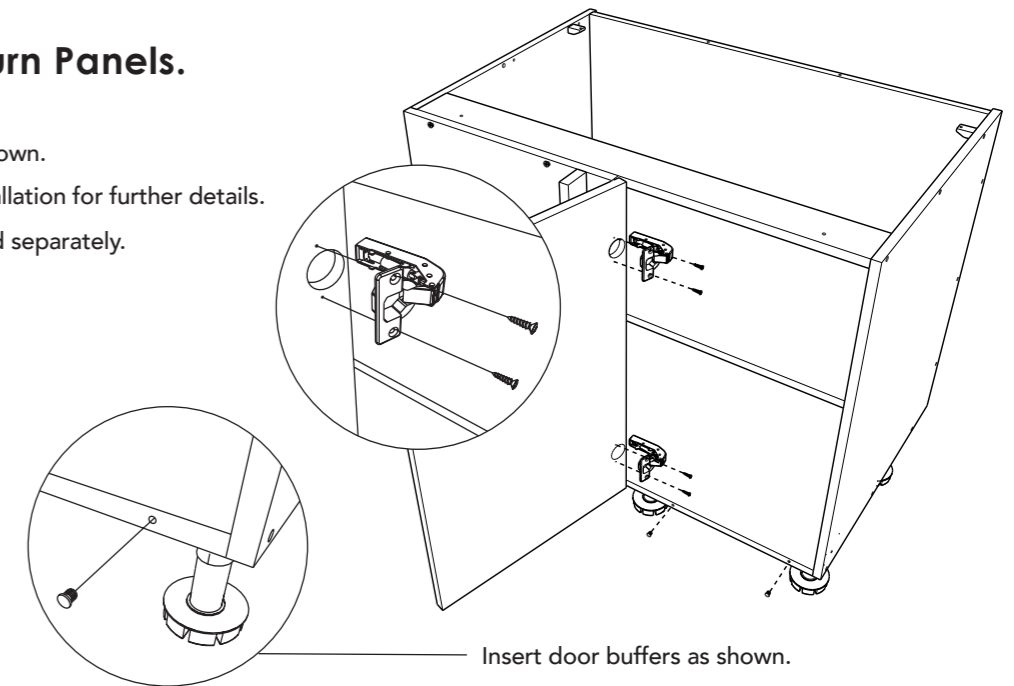
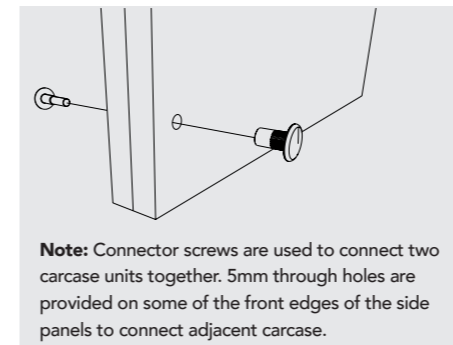

## 6. Shelf Placement & Bench Top Fixing.

- Insert the supplied shelf studs into the corresponding holes on the side panel to achieve the desired height. Shelves simply sit on the shelf studs.

**Note:** To fix the bench top at the rear of the unit, knock in the top fixing bracket as shown. Screw fix using 2 x 15mm screws. For the front fixing use 2 x 29mm counter sunk screws to fix the bench top to the cabinet through the front rail.

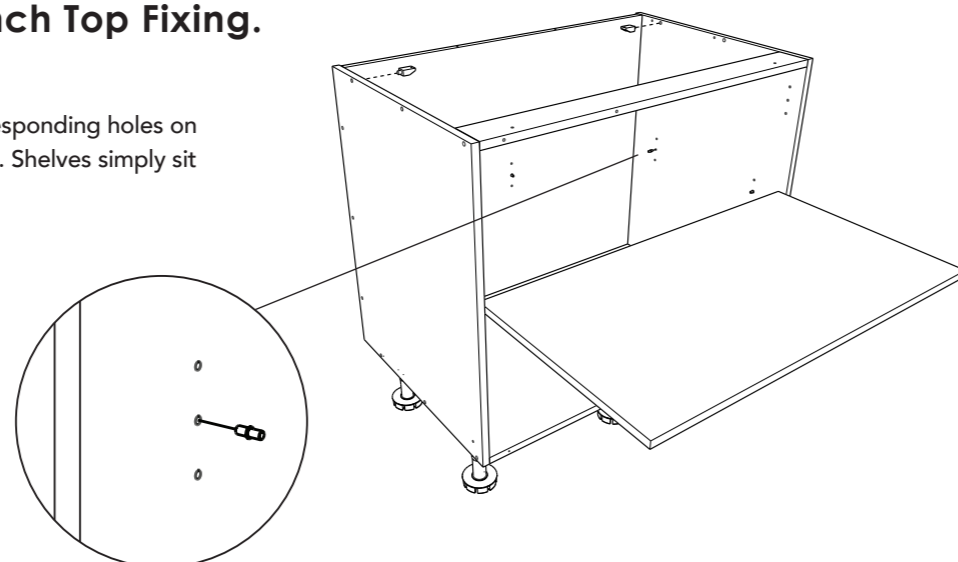

## 9. Hinge Installation & Adjustments.

- Hook the hinge into the front of the mount.

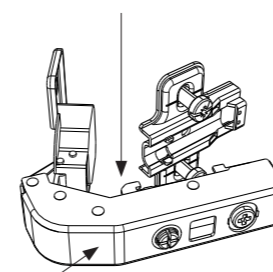

- Push the back down onto the hinge mount until you hear a click.

- Push this button to release the hinge from the mount.

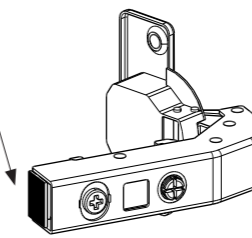

- Use these screws to adjust door up / down.

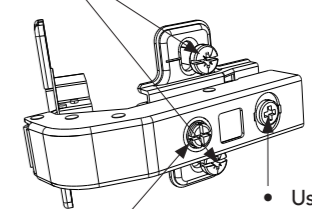

- Use these screws to adjust door in/out.

- Use these screws to adjust door right / left.