

INSTALLATION INSTRUCTIONS FOR "DEVON COTTAGE" "MINI" AND "SINGLE" FOLD DOWN CLOTHES LINES

IMPORTANT NOTICE

Please note: The wall brackets only fit one way. Before fixing, check the arms lock into position. If they do not lock, you have the wall brackets mounted upside down.

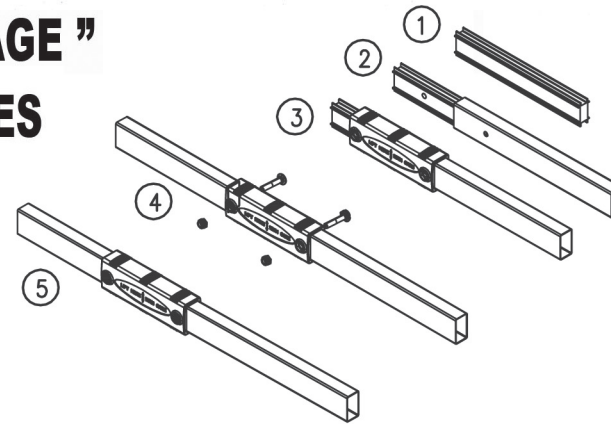

The front bar is conveniently shipped as two pieces. The centre joiner bracket ensures a snug fit when combining the bars.

"MINI" FOLD DOWN CLOTHES LINE WALL BRACKET CENTRES

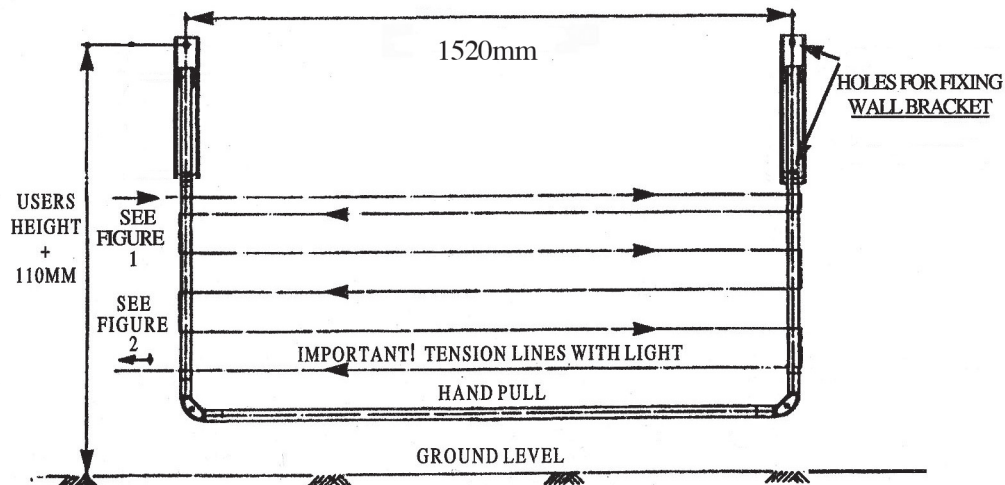

"SINGLE" FOLD DOWN CLOTHES LINE WALL BRACKET CENTRES

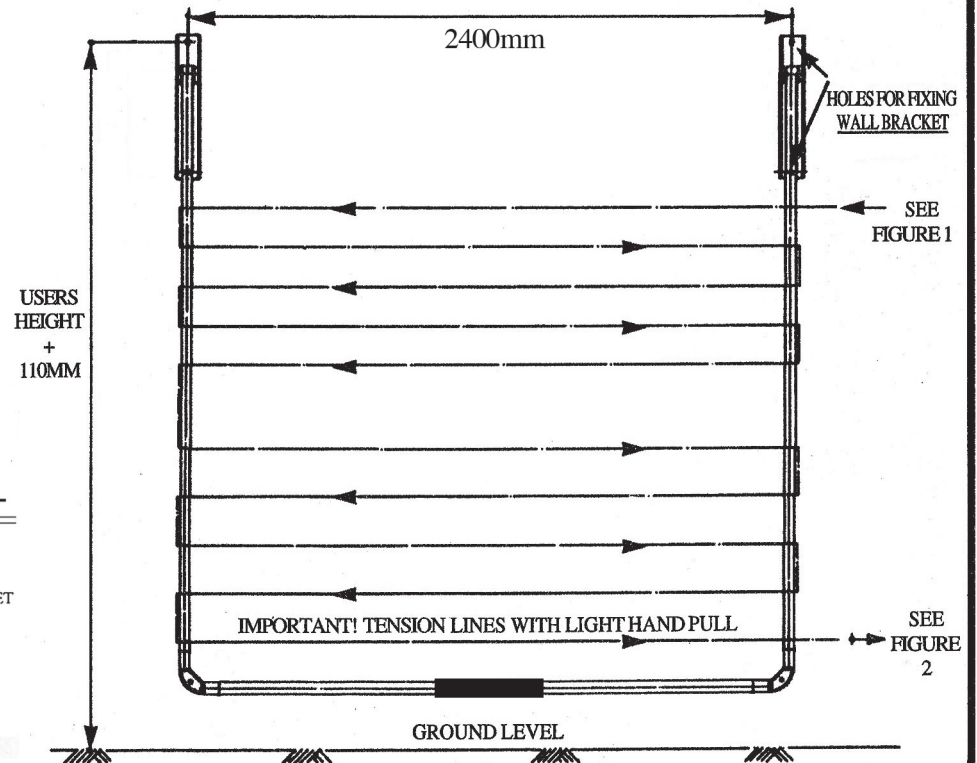

FIGURE 1
KNOT LINE
&
THREAD AS SHOWN

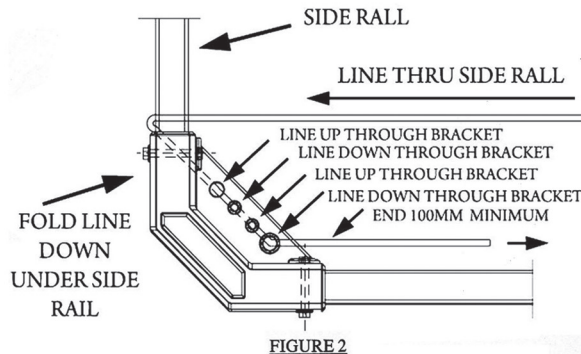
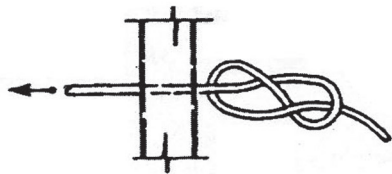

FIGURE 2

Due to on-going product development; arms, brackets and fixings may differ slightly from those pictured.



DEVON COTTAGE

To reduce the width or depth of a Devon Cottage fold down clothesline is very simple. If your individual requirements necessitate modification of the frame, then you'll need a ruler, pencil, hacksaw and drill to complete the task. The following seven steps show how easy it is to customise your existing Devon Cottage clothesline. If you intend to reduce the length of the front bar, you may wish to cut evenly from both ends which will ensure the joining handle remains in the centre of the bar.

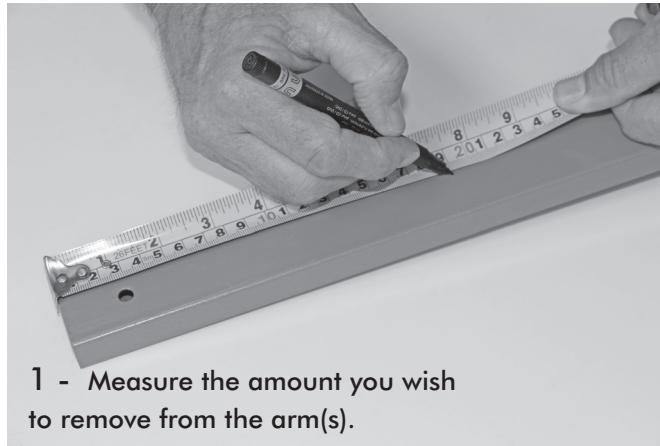

1 - Measure the amount you wish to remove from the arm(s).

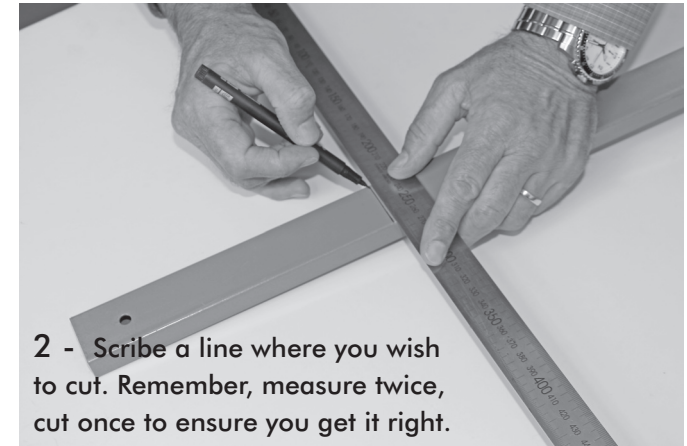

2 - Scribe a line where you wish to cut. Remember, measure twice, cut once to ensure you get it right.

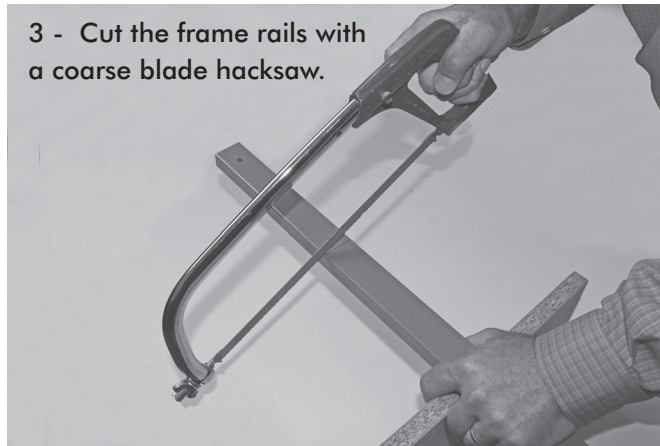

3 - Cut the frame rails with a coarse blade hacksaw.

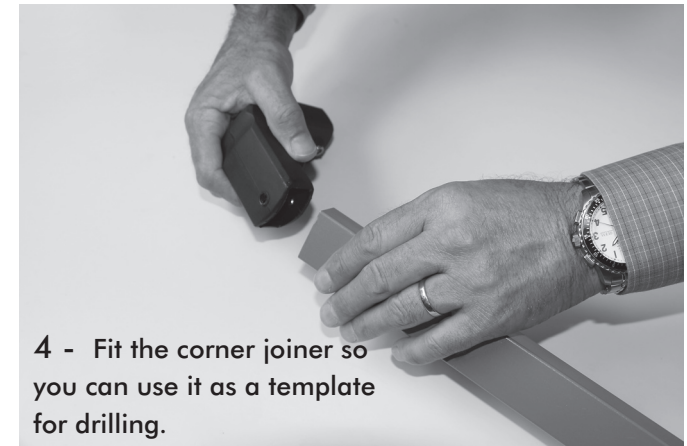

4 - Fit the corner joiner so you can use it as a template for drilling.



5 - Drill the inside hole using the existing hole in the corner bracket as a template.

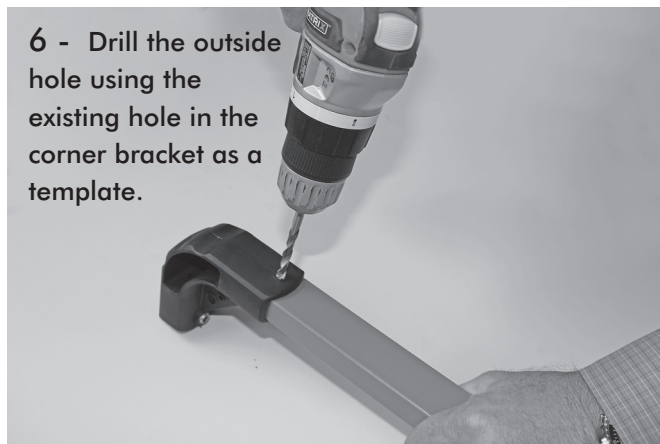

6 - Drill the outside hole using the existing hole in the corner bracket as a template.



7 - Finally insert the supplied bolt & tighten the nut to complete the modification of your fold-down.