

FLOOR TOWER

Assembly Instructions

Art. 730.83.213

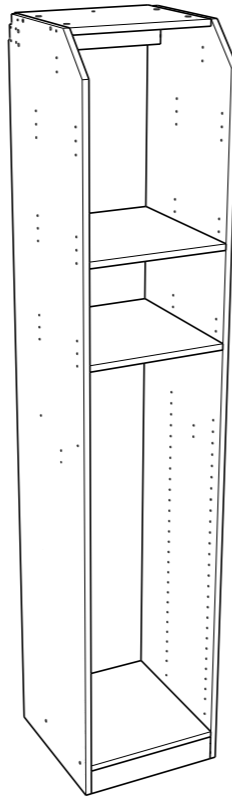

Wardrobe Panels included.

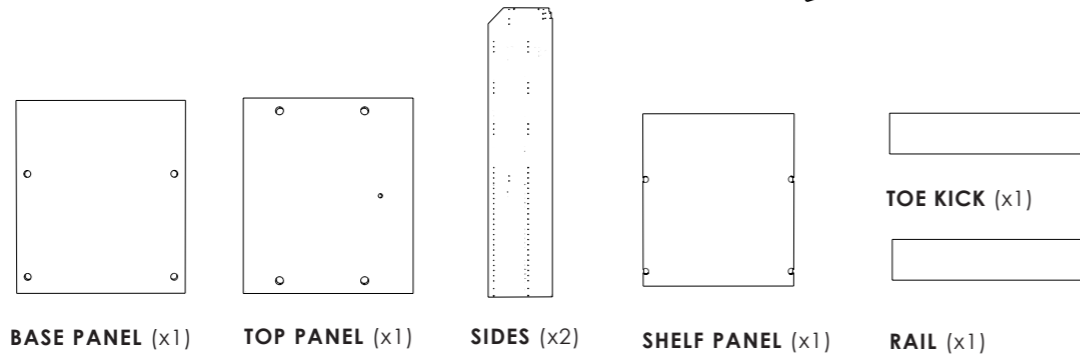

H'AFELE Hardware included.

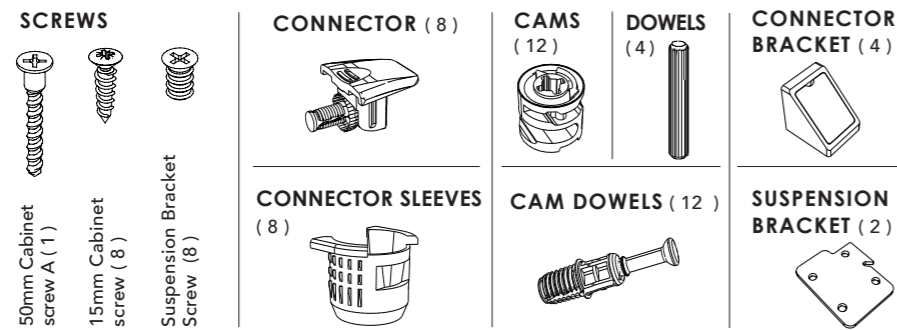

Required Tools.

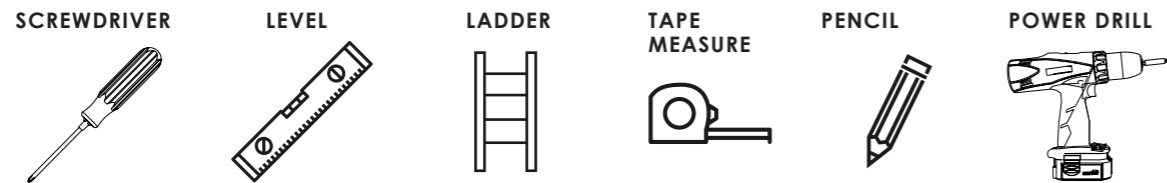

Handy Note: Please read the instructions carefully before you start and make sure to identify the parts you need for each step. When assembling it is best to do on a soft surface to prevent damage.

Manufactured in New Zealand for: Mitre 10 New Zealand Limited.



1. Fitting Hardware to Tower Sides.

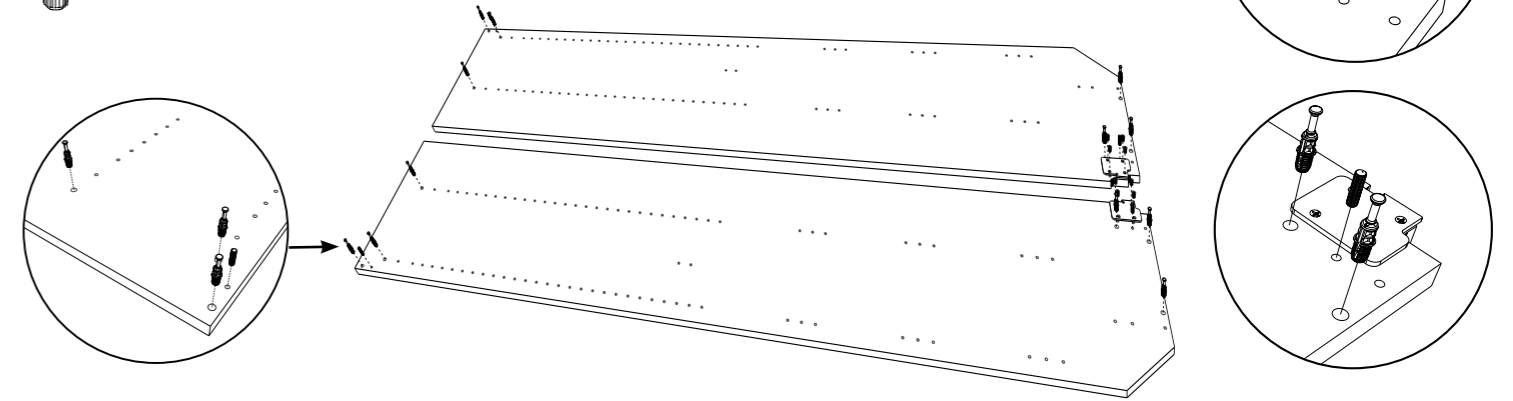
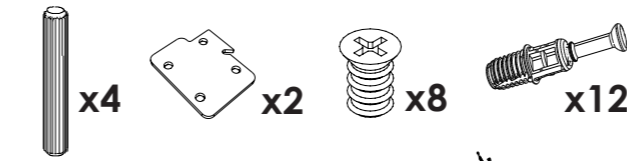

2a. Assembling Tower Unit Panels.

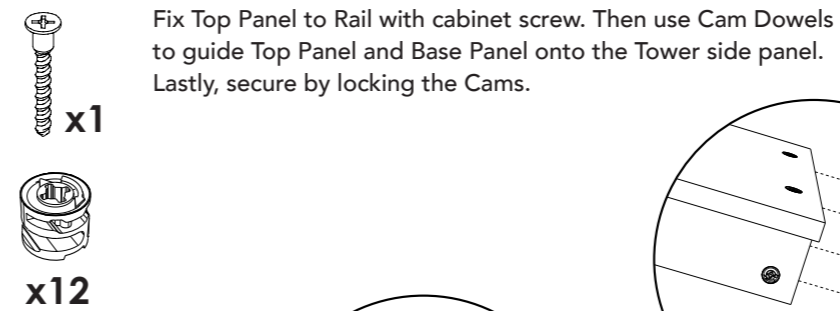

Fix Top Panel to Rail with cabinet screw. Then use Cam Dowels to guide Top Panel and Base Panel onto the Tower side panel. Lastly, secure by locking the Cams.

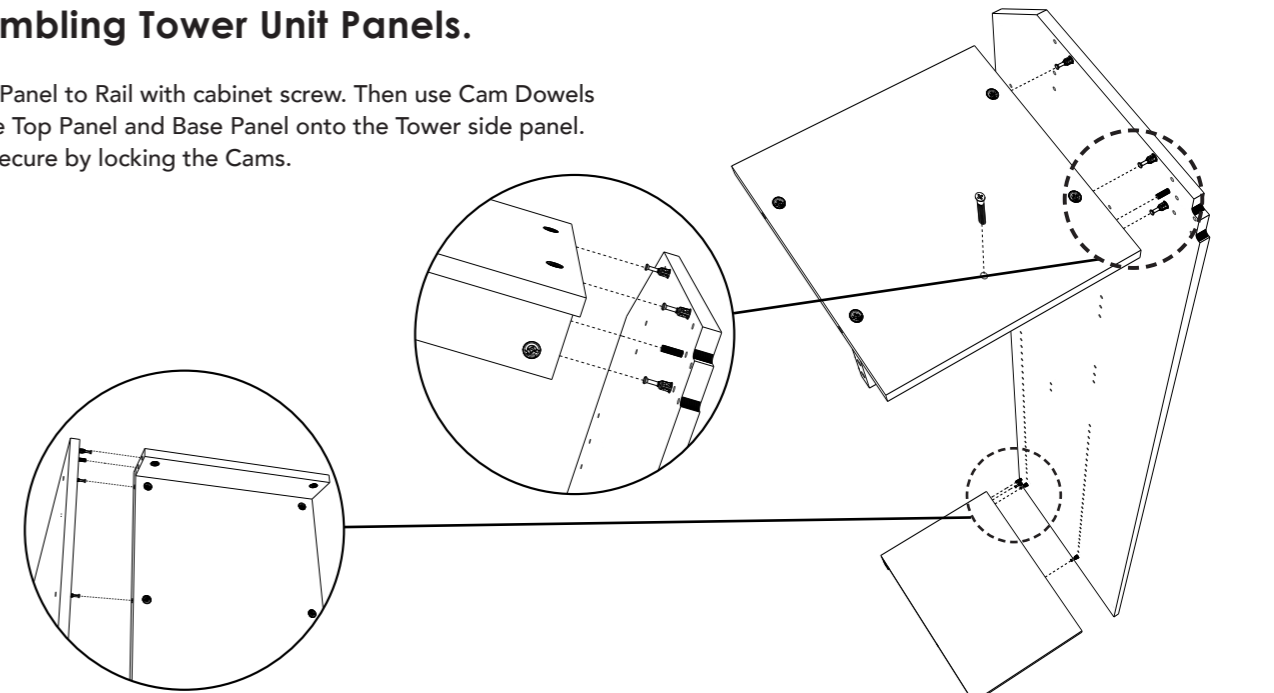

2b. Attach right hand Tower Panel to above Tower assembly.

Lock Cams by turning cams as shown:

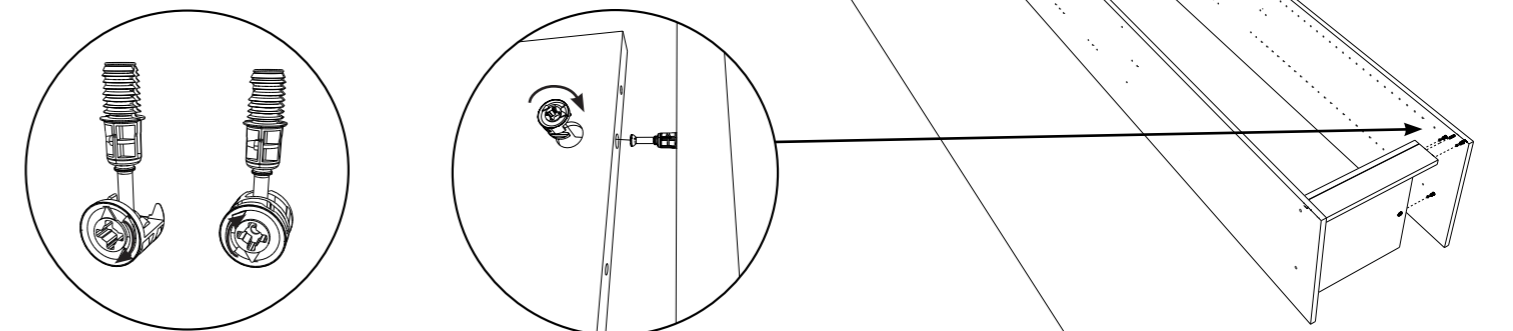

3. Insert Connectors for two Tower Shelves at preferred height.

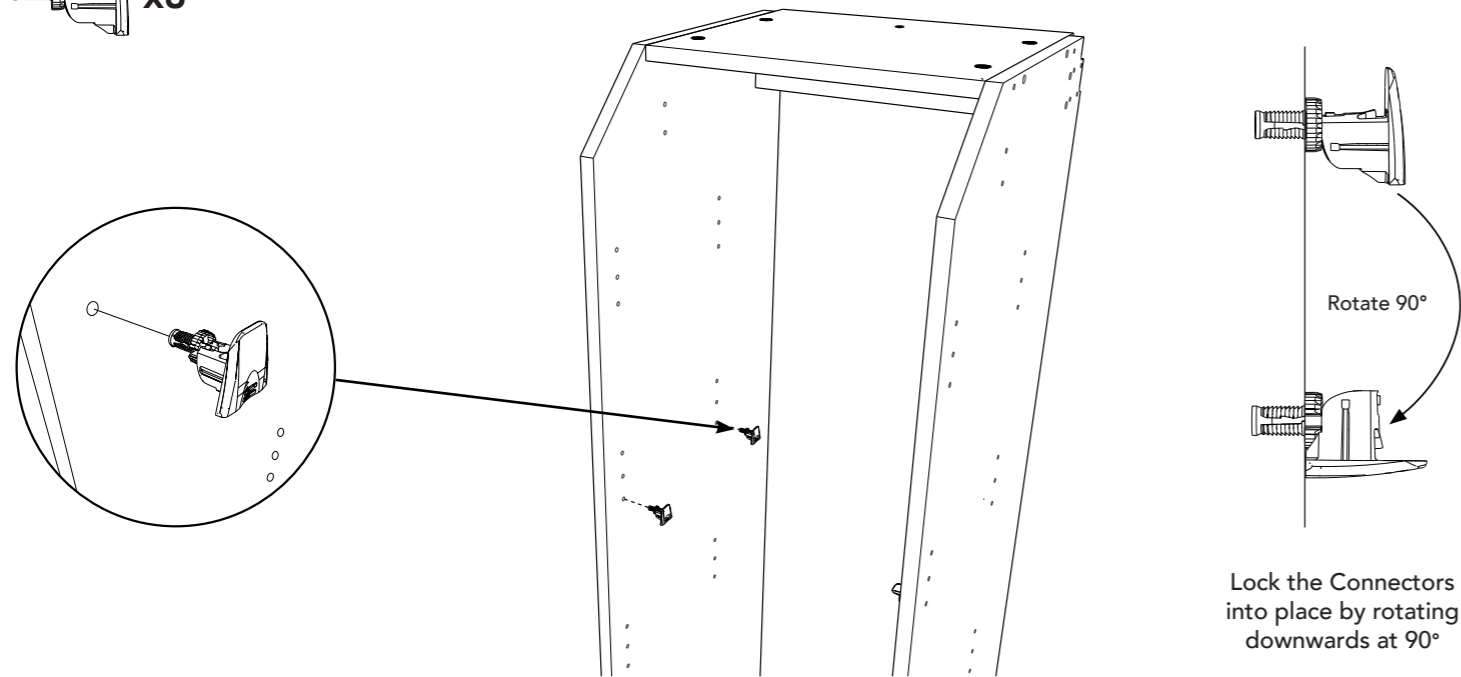
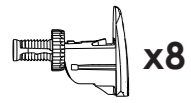

* Repeat for second shelf.

4. Insert Connector Sleeves onto the two Tower Shelves. Then place shelf onto Connectors.

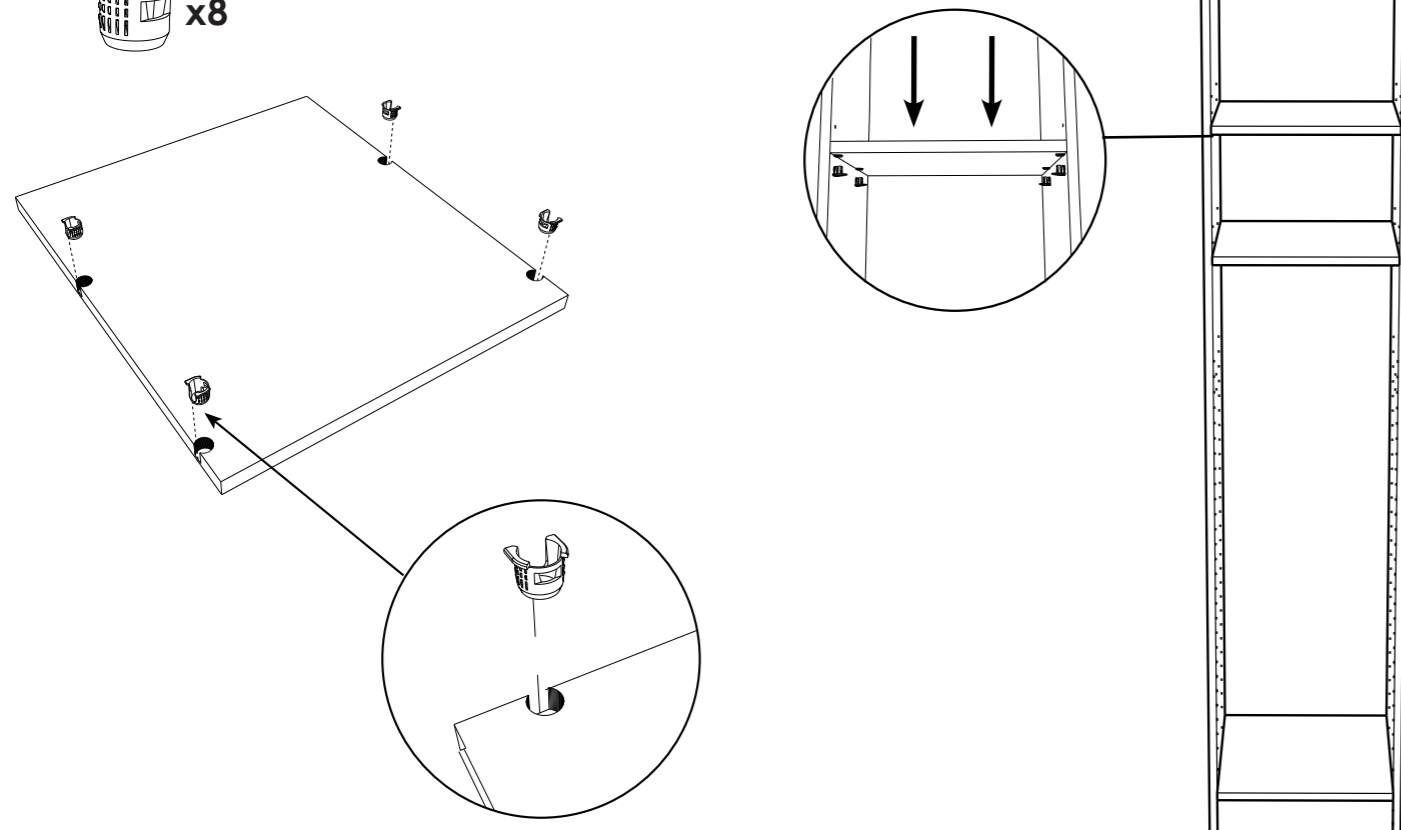

5. Fixing the Suspension Rail.

- * Suspension Rail is sold separately.
- * Purchase appropriate wall fixings for your wall material separately.

Important Note.

Ensure when fixing the Suspension Rail that it is not only level, but fixed to a wall that is straight and true.

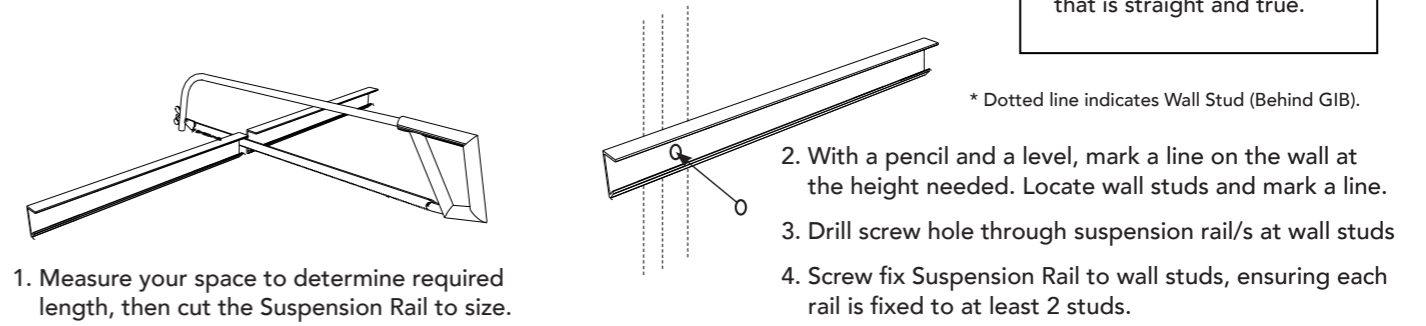

6. Fixing Tower Unit and Connector Brackets.

Lift Tower Unit and End Panel onto the Suspension Rail in the desired position. Use Connector Brackets to secure bottom of tower to prevent movement of the Tower Unit, these must also be fixed to wall studs.

