

# BASE CABINET 3 DRAWER UNIT

## Assembly Instructions

Suitable for Base Cabinet  
BD60D2P-IMP, BD80D2P-IMP,  
BD90D2P-IMP

732.25.817

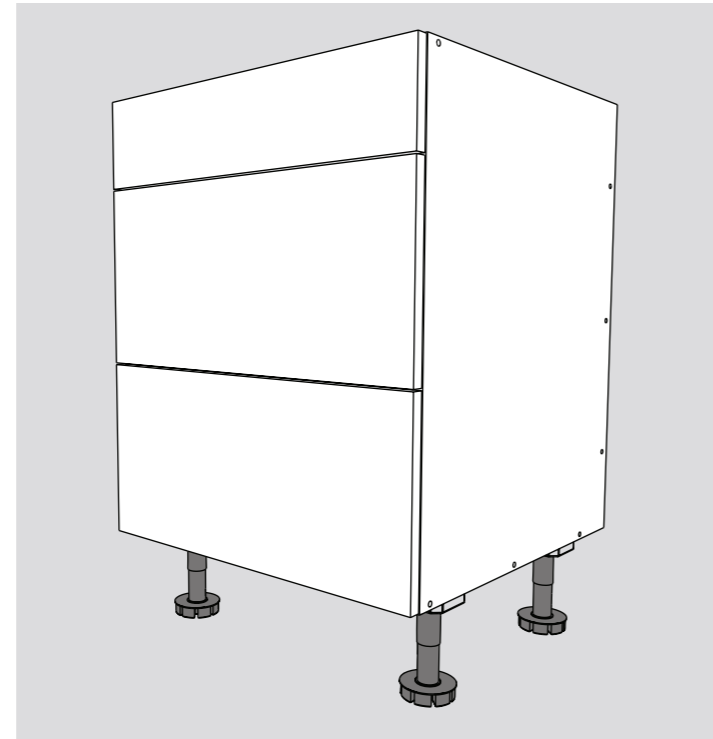
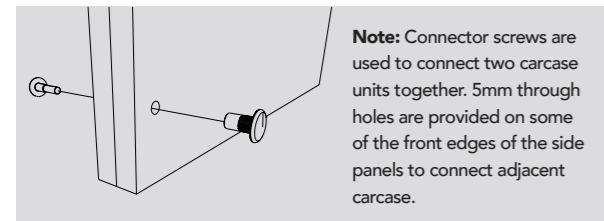

**Handy Note:** Please read the instructions carefully before you start and make sure to identify the parts you need for each step. When assembling it is best to do on a soft surface to prevent damage.

### Cabinet Panels included.

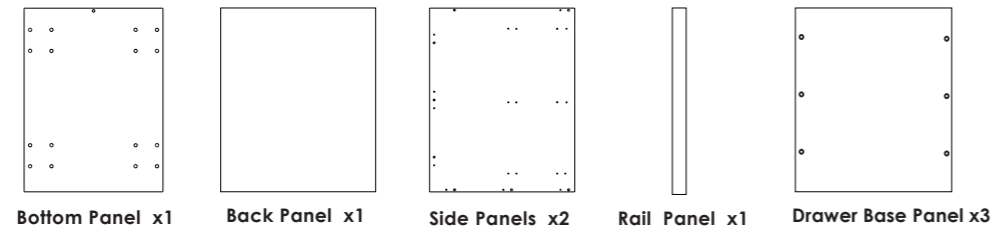

### HÄFELE Hardware included.

**Legend**  
A. = BD60D2P-IMP  
B. = BD80D2P-IMP  
BD90D2P-IMP

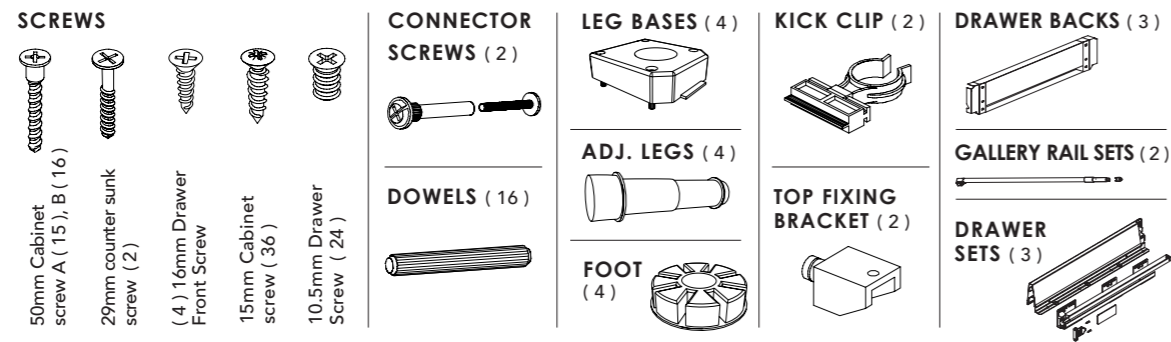

### Required Tools.

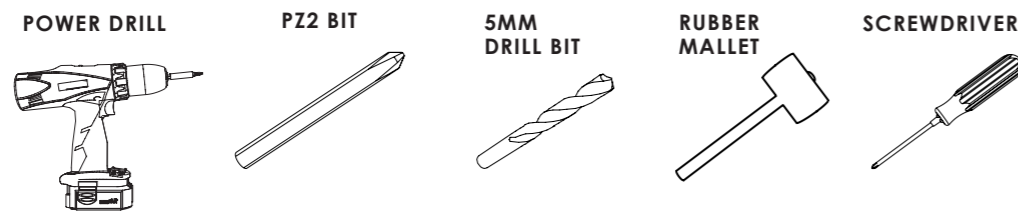

### Handy Tools.



## 1. Installing Leg Bases.

- Fix the Leg bases by aligning them on the base panel as shown.
- Ensure dowels in the leg bases line up with the holes. Use a block of wood between leg base and mallet to prevent damage before striking it into place.

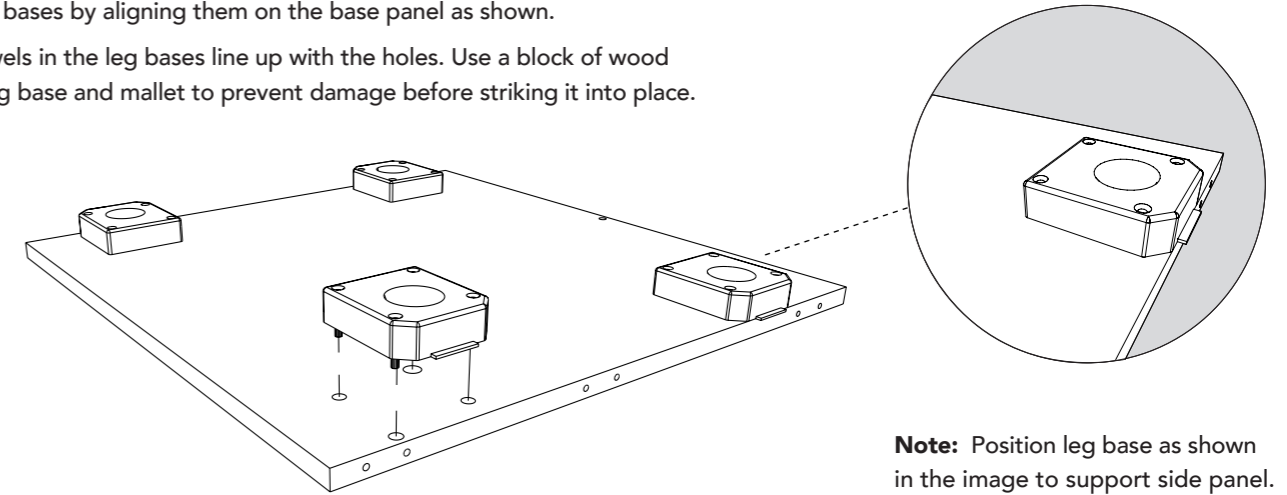

## 2. Fixing Bottom and Back Panel.

- Lay the back down flat as shown.
- Use 50mm Cabinet Screws to fix the bottom panel to the back panel.

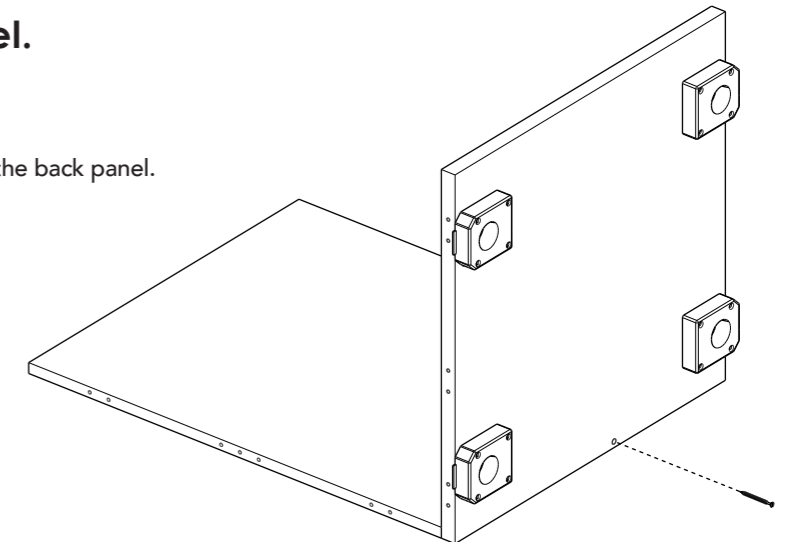

## 3. Inserting Dowels into Side Panels

- While laying the panels flat, insert the dowels into the correct holes as marked in the image shown.

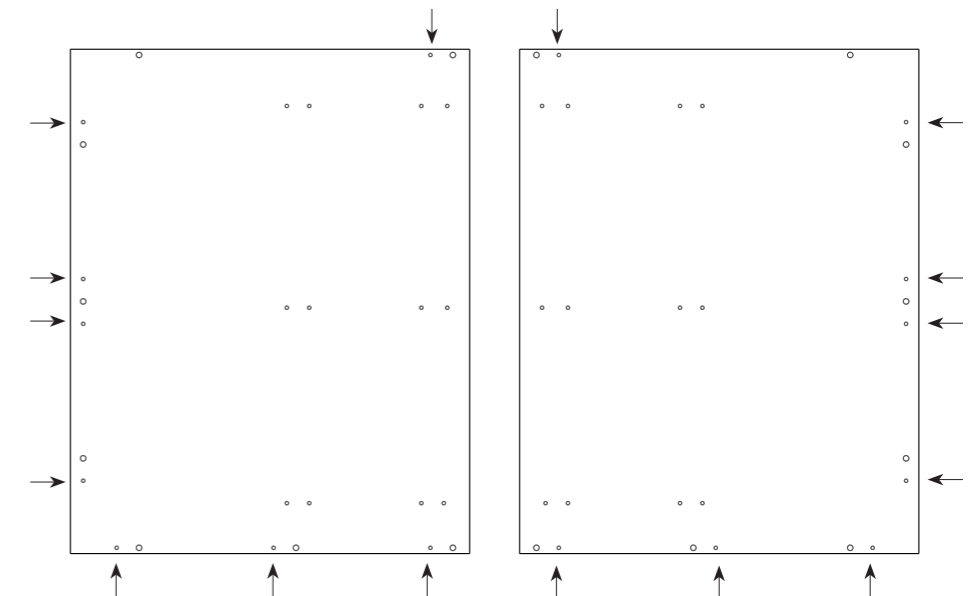

## 4. Fixing The Runners to Side Panels.

- Fix the runners onto the side panels with the supplied Drawer Screws.
- The third hole on the runner should line up with the first hole on the side panels as shown in the image below.

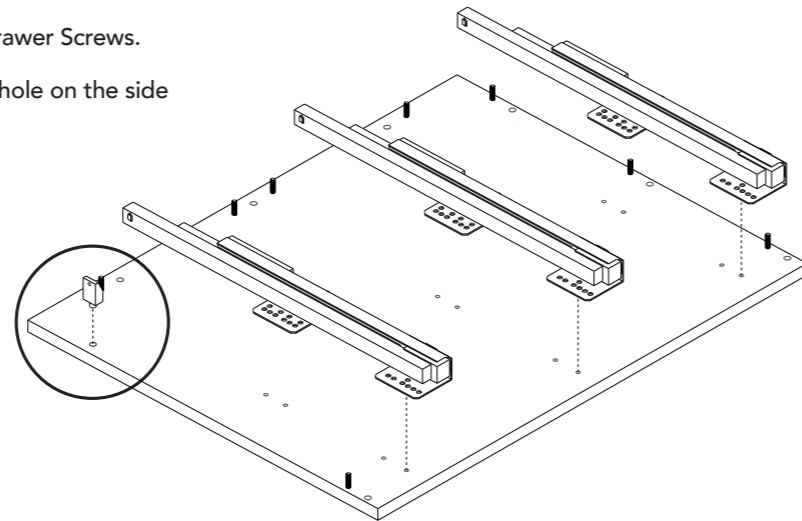
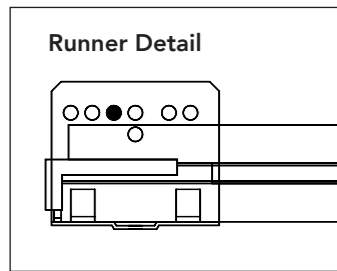

- **Note:** 1 x 15mm Cabinet screw used per bracket to fix benchtop to the cabinet.

## 5. Fixing Side Panels to Back and Base.

- Align the base and back panel onto the dowels on the side panel.
- Align the rail onto the correct dowels as shown in the image.
- Lift and align the second side panel to ensure dowels are aligned with the corresponding holes. Use 50mm Cabinet Screws to fix the rail, back and bottom to the side panel.
- Flip the cabinet to secure the other side panel with back, base and rail panel using 50mm Cabinet Screws.

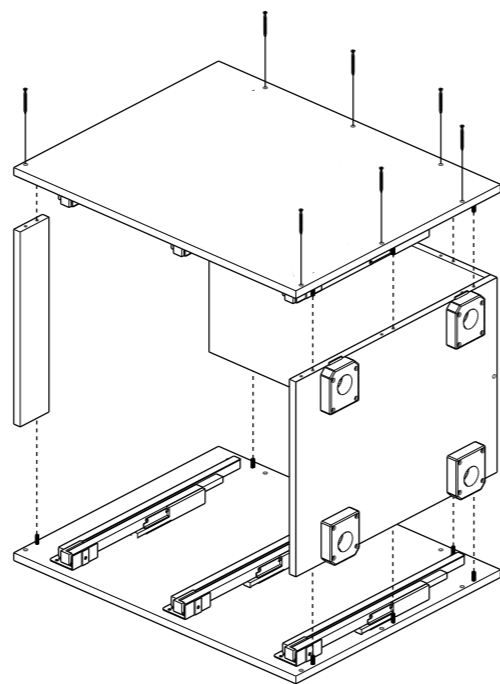

## 6. Fixing leg and foot to leg base.

- **Cabinet Feet:** Push the supplied adjustable leg into the foot and then insert it into the leg base attached to the base panel.

- Height of the Adj Legs =  $\pm 150\text{mm}$
- Height of the Cabinet = 720mm
- Height of Cabinet + Adj Legs = 870mm

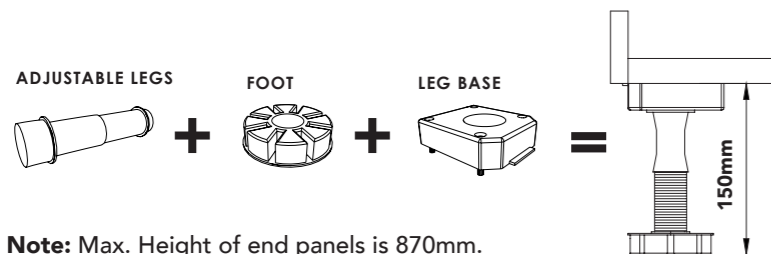

**Note:** Max. Height of end panels is 870mm.

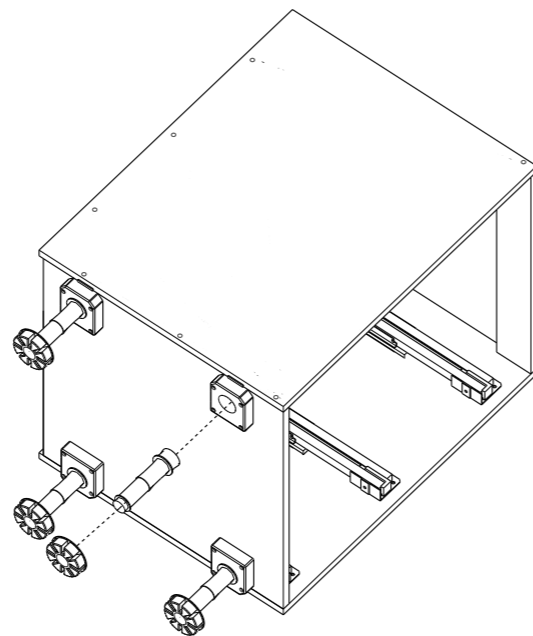

## 7. Assembling the drawers.

- Slide the back into the drawer sides until you hear a click sound as shown in the image. (Large backs are for pot drawers).
- Slide the drawer base into place as shown in the image below.
- Flip the drawer unit as below, and screw drawer sides to the base using 15mm screws. Finish by securing back into drawer base using 15mm screws.

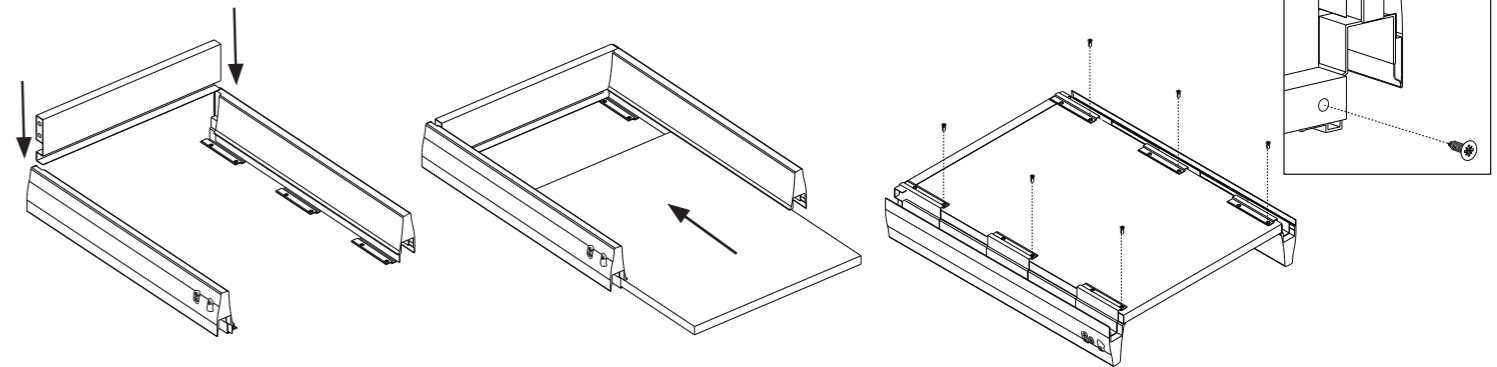

## 8. a. Installing the drawer fronts.

1. Using a screw drive, fit the drawer front mounting clips onto the drawer front, using the 16mm drawer front screws on the prick marks on the front as your guide

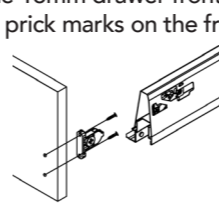

2. Clip drawer front into the slots of the side until it locks in.

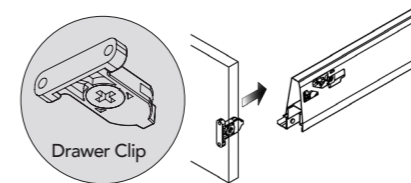

3. To remove the front, remove the cap and undo the clip using a screwdriver.

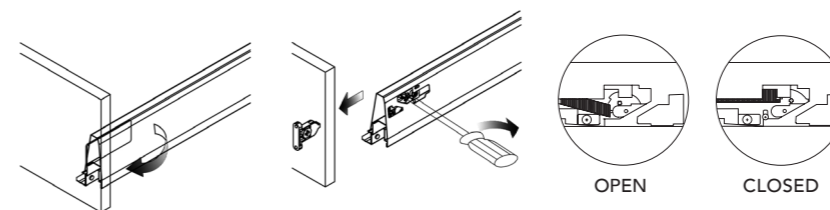

## b. Installing the Gallery Rails.

1. Clip the gallery rail to the back panel.
2. On selected drawer fronts, use the prick marks above the drawer clip, and screw the gallery rail connector to the drawer front with the 15mm screws. Then clip the gallery rail on.

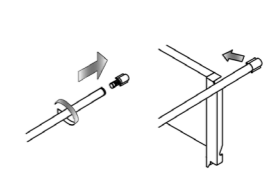

3. Slide plastic cover over front connector.

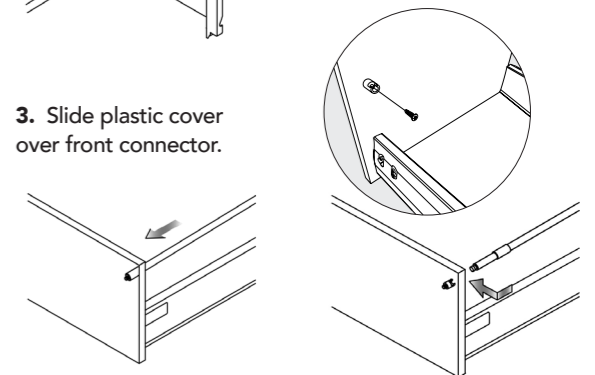

## 9. Drawer Installation & adjustments.

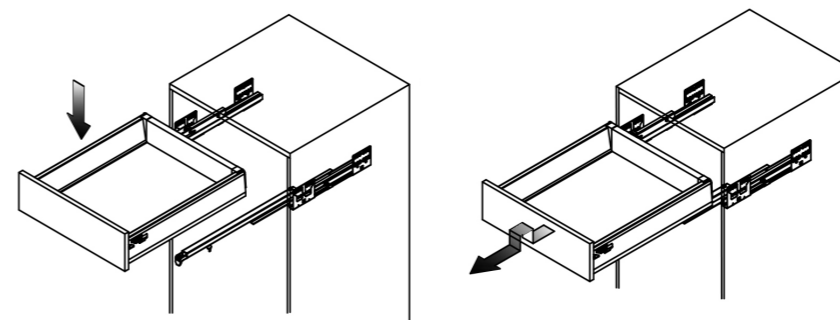

- Slide out the slides, and place the drawer in from above onto slides.
- Lift the drawer up to dismantle

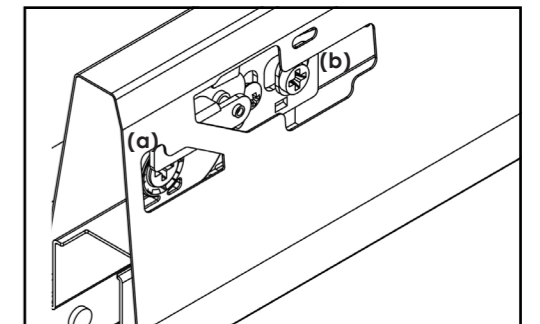

- (a) Use to adjust drawer front left or right.
- (b) Use to adjust drawer front up and down.