

## SHELF PACK

### Assembly Instructions

Suitable for all Towers (A),  
Wardrobe (B) and  
End Pack (C) Shelves:

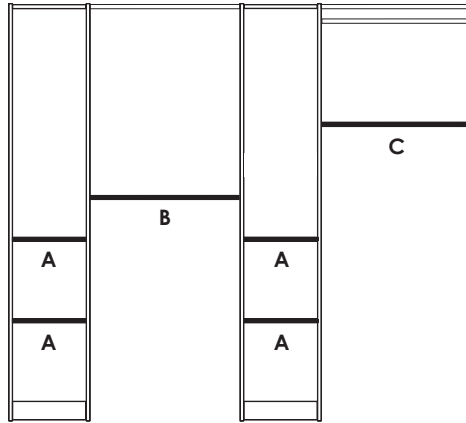

Art. 730.83.219

### Wardrobe Components included.

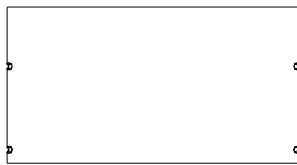

SHELF (x1)

### HÄFELE Hardware included.

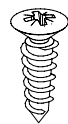

CABINET  
SCREWS  
(C,x4)



'L' BRACKET  
(C,x2)

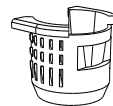

CONNECTOR SLEEVES  
(A, B&C x4)

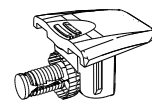

CONNECTOR  
(A, B&C x4)

### Required Tools.



SCREWDRIVER

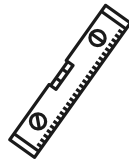

LEVEL



LADDER

**Handy Note:** Please read the instructions carefully before you start and make sure to identify the parts you need for each step. When assembling it is best to do on a soft surface to prevent damage. **Your Connex 15 Year Home Use Warranty will not apply to incorrectly assembled and/or installed product. Follow the advice of your selected wall fixings (sold separately) to ensure suspension rail can support loaded wardrobes.**

Manufactured in New Zealand for: Mitre 10 New Zealand Limited.



# 1. Inserting the Connector Sleeve.

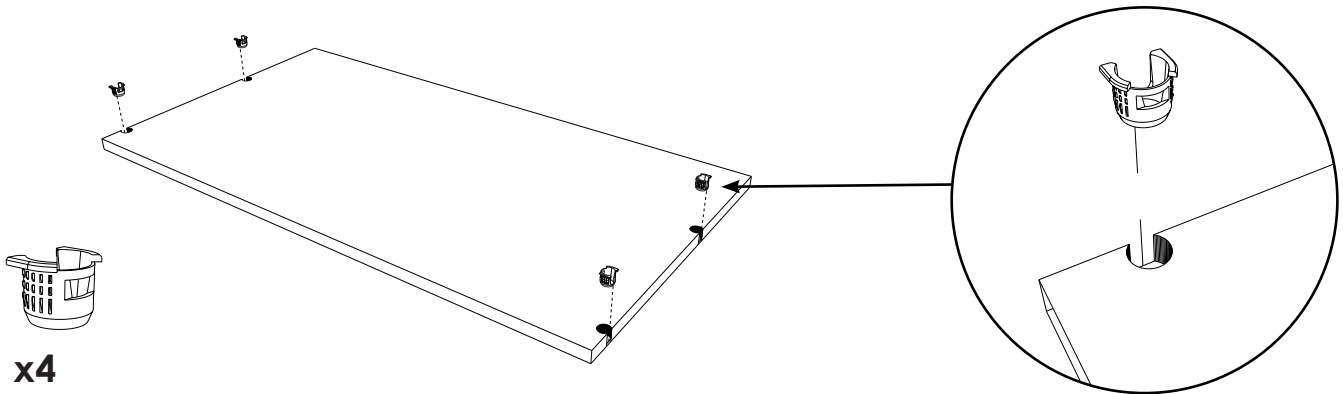

# 2. Inserting the shelf connector.

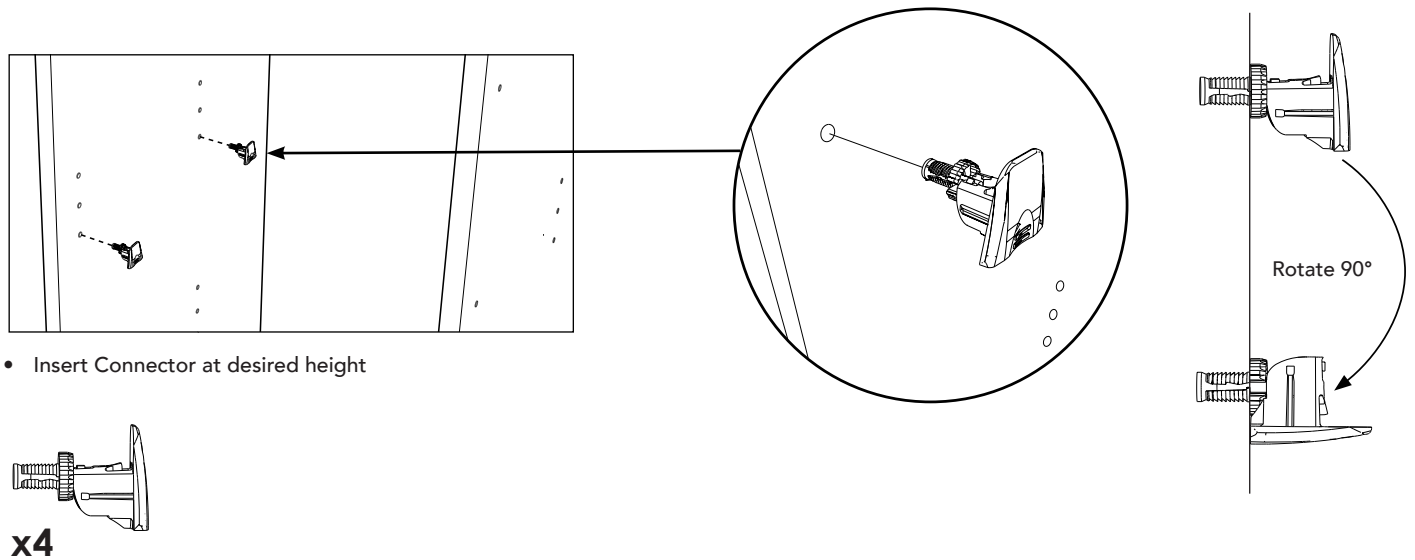

# 3a. Place Shelf onto the Connectors.

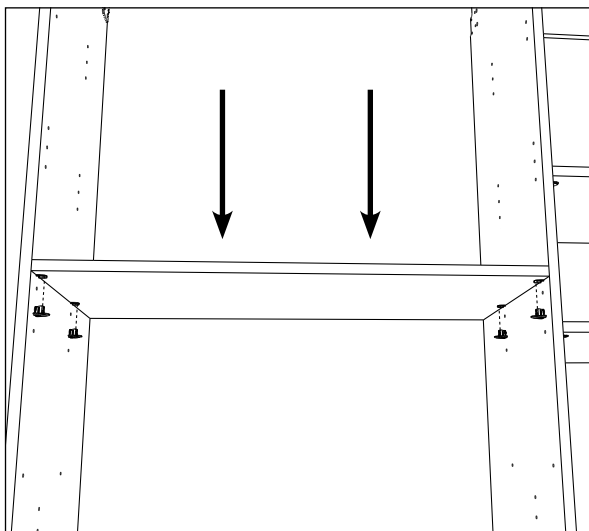

# b. Trimming shelf to suit wall adjustment if needed

End Pack Shelf ( C ) only.



x2

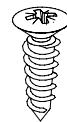

x4

