



# BUILD YOUR OWN SPORTS ARENA

**CAUTION:** Kit contains components with functional sharp points. Adult supervision required. Please dispose of any components if they become damaged after assembly. Use safety goggles at all times. Small parts: not suitable for children under three years.



This product contains a small ball which may present a choking hazard. Not suitable for children under 3 years.

## MATERIALS:

2 Bottom short pieces

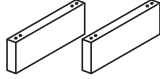

2 Bottom long pieces

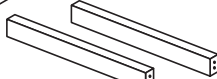

1 Base panel



4 Top short pieces

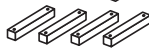

2 Top long pieces

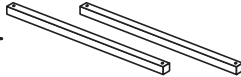

2 Players



2 Balls



2 Control rods with magnets



22 Nails



**1** Attach the bottom short pieces to the bottom long pieces using eight nails.

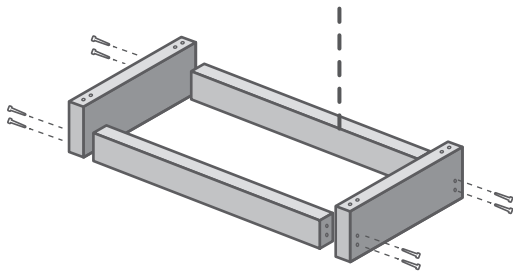

**2** Lay the base panel on the top of the structure while lining up the nail holes.

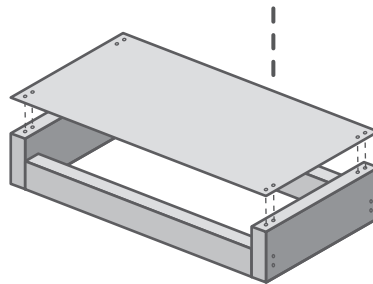

**3** Attach 4 top short pieces to the structure using 8 nails.

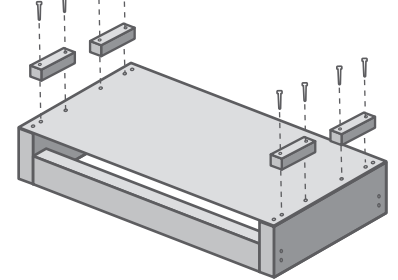

**4** Attach 2 top long pieces to the structure using 4 nails.

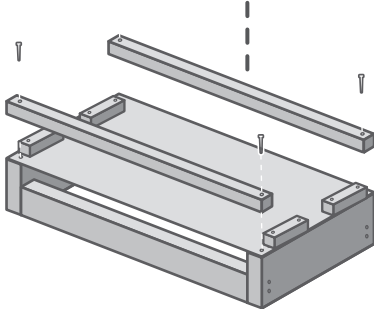

**5**

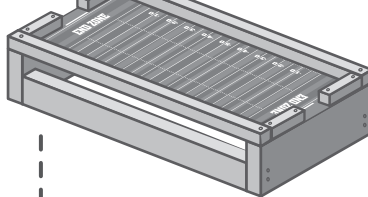

Attach your stickers based on the sport that you want to play.

**6**

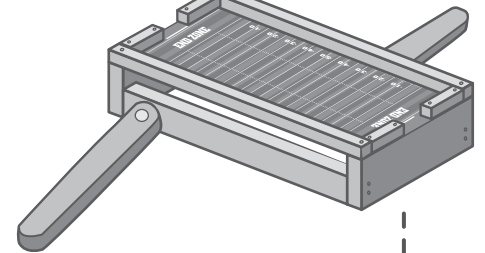

Insert the control rods through the open sides of the structure (magnets facing up)

**7** Place the players on the panel over the magnet in the control rod.

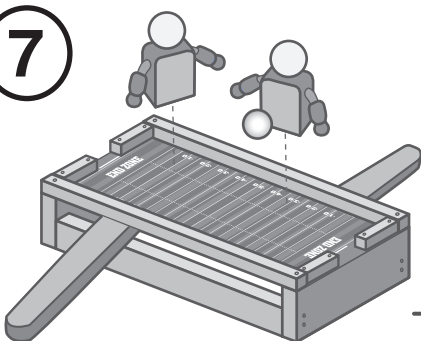

**8**

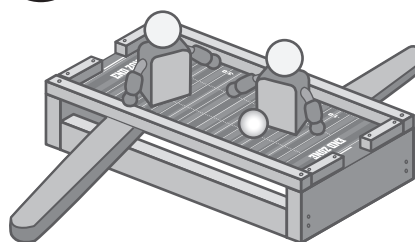

**FINAL:**

Add stickers and enjoy playing with your easy as kids sport arena.